



4D SYSTEMS

Modules On The Go Series

MOTG-GPS

Pluggable μ SD GPS Module

Data Sheet

Document Date: 4th January 2011
Document Revision: 1.0



Description

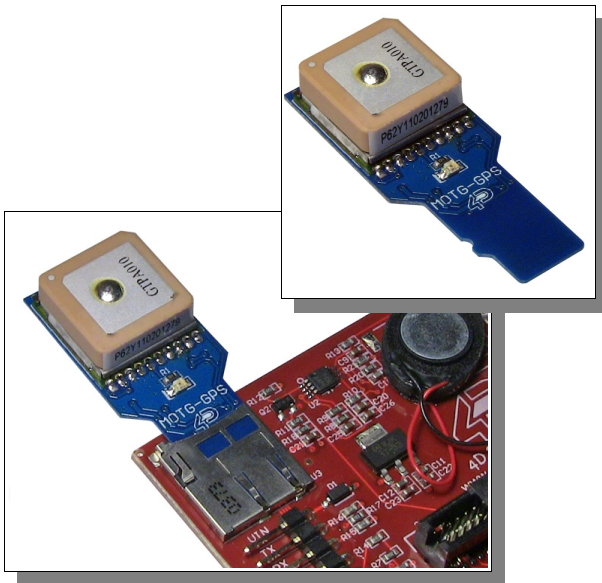

MOTG-GPS is a small pluggable GPS module ideally suited for embedded systems. It incorporates a complete solution GPS engine module with an integrated finely tuned highly sensitive Patch-On-Top (POT) ceramic antenna and has a wide range of uses in educational, experimental as well as during any development phase where a quick GPS solution is required. It comes in a micro-SD memory card format which is designed to interface to any embedded platform that has an on board micro-SD (or SD) card adaptor.

Complete NMEA messages as well as specific information such as Longitude, Latitude, Heading, Time, Date, Speed and many more features are built inside the MOTG-GPS. The module utilises the standard SPI signals and acts as a slave device to the host micro. It offers a simple yet effective command set to any host platform that can communicate via a SPI port and all GPS related commands are sent using a simple protocol.

MOTG-GPS device simply plugs into a standard μ SD/SD socket for quick assembly and maintenance, no need to solder and end up with a wiring nest. Don't need the device permanently, or want to make it optional? Simple, just unplug.

The MOTG-GPS is a novel concept from 4D Systems that belong to a broader range of **Modules-On-The-Go** series. Some of the other modules on offer are:

- **MOTG-96:** Pluggable 0.96" 96x64 OLED display module in a micro-SD card format.
- **MOTG-128:** Pluggable 1.5" 128x128 display module in a micro-SD card format.
- **MOTG-RF24G:** Pluggable 2.4Ghz RF Transceiver module in a micro-SD card format.
- **MOTG-WiFi:** Pluggable Wifi module in a micro-SD card format.
- More modules coming very soon....

Features

- Low-cost pluggable GPS module.
- Easy micro-SD card form factor that will plug into any embedded host platform that has a micro-SD or SD card adaptor.
- SPI interface to the host via the micro-SD or SD adaptor.
- Comprehensive set of built in high level GPS commands.
- Based on MediaTek Single Chip Architecture, MT3329.
- Patch Antenna Dimensions : 15mm x 15mm x 4mm.
- L1 Frequency, C/A code, 66 channels.
- High Sensitivity : Up to -165dBm tracking, superior urban performance.
- Position Accuracy : < 3m CEP (50%) without SA (horizontal).
- Supports up to 210 PRN channels.

- Jammer detection and reduction.
- Multi-path detection and compensation.
- Cold Start : under 35 seconds (Typical).
- Warm Start : under 34 seconds (Typical).
- Hot Start : under 1 second (Typical).
- Supports NMEA0183 V3.01 data protocol.
- RoHS Compliant.



Note: MOTG-GPS has a Red LED indicator at the front of the module. This LED will blink when the module is trying to lock and get a fix. Once it has established a successful lock the LED will turn off.

Table of Contents

1. Pin Configuration and Description	5
2. micro-SD SPI Hardware Interface	6
2.1 Generic Host Master SPI Timing	6
2.2 MOTG-GPS Slave SPI Timing Diagram	7
3. Software Interface	8
3.1 Command Protocol – Flow Control	8
4. Command Set	9
5. NMEA Messages	33
6. Development, Support and Test Tools	39
6.1 MOTG Programming Cable and Adaptor.....	39
6.2 4D Embedded GPS Software Test Tool.....	39
6.3 Programing the MOTG with a PmmC File.....	40
6.4 micro-SD to SD Adaptor.....	40
7. Specifications and Ratings	41
Proprietary Information	42
Disclaimer of Warranties & Limitation of Liability	42
Contact Information	42

1. Pin Configuration and Description

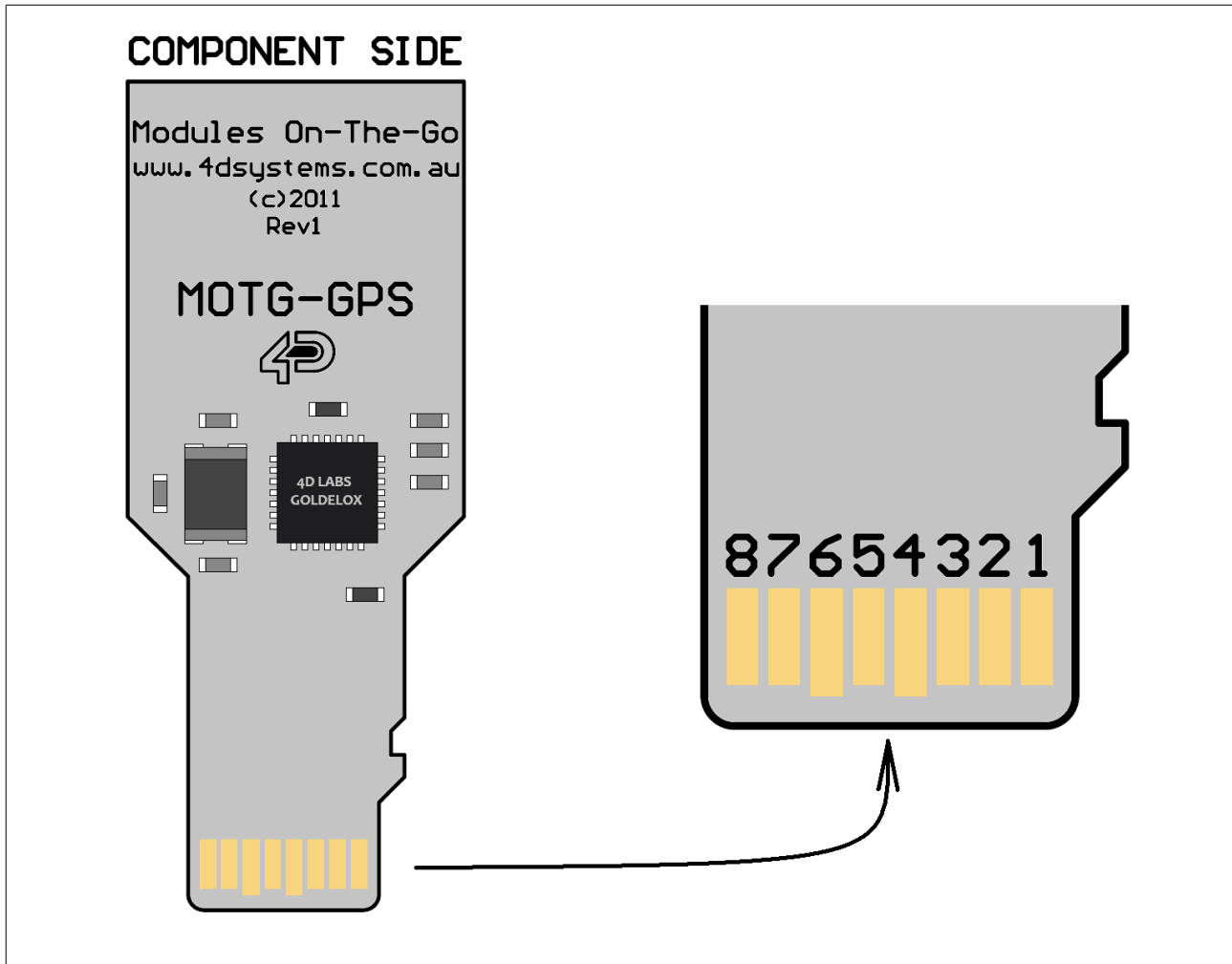

Pin	Symbol	I/O	Description
1	N.C.	--	Not Connected.
2	CS	I	MOTG SPI Chip Select. The host asserts this signal LOW when accessing the display module.
3	SDI	I	MOTG SPI Data In. This pin connects to the Data Out of the host SPI.
4	3.3V	P	Voltage supply input. Range is 3.0V to 3.6V, nominal 3.3V.
5	SCK	I	MOTG SPI Clock In. This pin connects to the host SPI Clock output.
6	GND	P	Ground.
7	SDO	O	MOTG SPI Data Out. This pin connects to the host SPI Data input.
8	RESET	I	MOTG Reset Input (active LOW). This pin is only used by the Programming module for updating the MOTG with PmmC files. Not used during normal operation.

Legend: I = Input, O = Output, P = Power

2. micro-SD SPI Hardware Interface

The MOTG-GPS is designed to plug into standard micro-SD card sockets employed in most embedded platforms. It can also plug into standard SD slots with the aid of a micro-SD to SD adaptor. It is important to note that the communication interface is via standard SPI signalling and most embedded platforms employ the SPI mode for their on board memory card sockets. The following timing diagrams provide detailed information about the required SPI signalling.

Note1: MOTG-128 supports a maximum clock rate of 12Mhz.

Note2: MOTG-128 will not work with external or built in PC card readers. These devices do not utilise the SPI signalling as required by the MOTG devices.

2.1 Generic Host Master SPI Timing

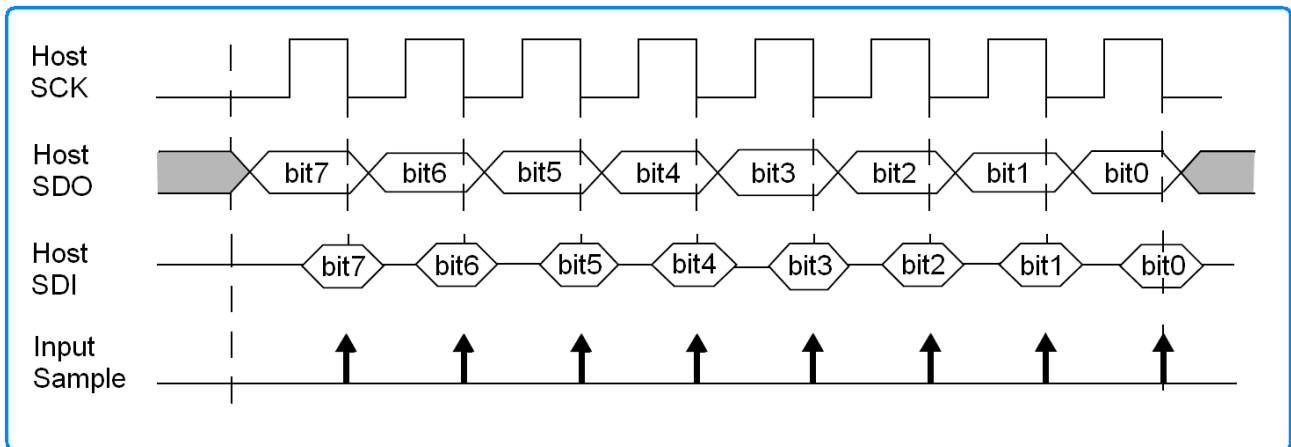

2.2 MOTG-GPS Slave SPI Timing Diagram

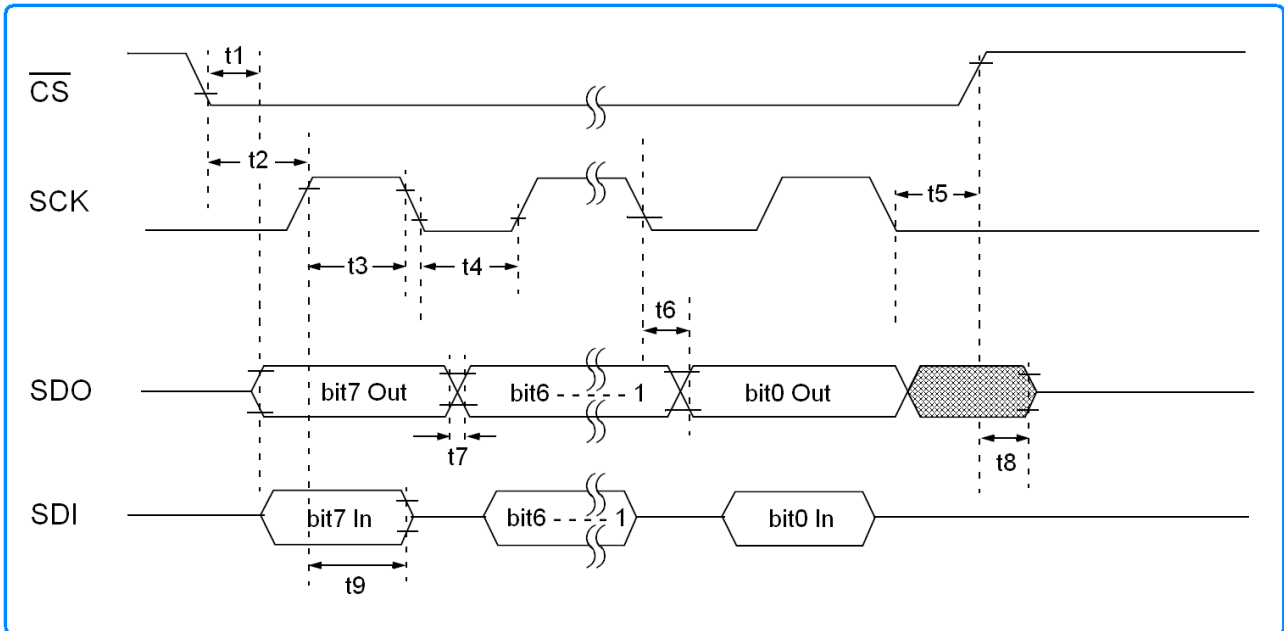

Item	Symbol	Min.	Typ.	Max.	Unit
SDO Data Output Valid after CS↓ Edge	t1	--	--	50	ns
CS↓ to SCK↑ Input	t2	100	--	--	ns
SCK Input High Period	t3	40	--	--	ns
SCK Input Low Period	t4	40	--	--	ns
CS↑ after SCK Edge	t5	190	--	--	ns
SDO Data Output Valid after SCK Edge	t6	--	--	50	ns
SDO Data Output Rise and Fall Period	t7	--	--	25	ns
CS↑ to SDO Output High-Impedance	t8	10	--	50	ns
Hold Time of SDI Data Input to SCK Edge	t9	100	--	--	ns

3. Software Interface

The MOTG-GPS module is a slave peripheral device and it provides bidirectional communications to a host controller via its SPI interface. All communications between the host and the device occur over this SPI interface. The protocol is simple and easy to implement.



Note: The host must initialise its SPI port as the master and must meet the MOTG SPI specifications outlined in the previous section.

3.1 Command Protocol – Flow Control

The MOTG modules are slave devices and all communication and events must be initiated by the host. Each command is made up of a sequence of data bytes. When a command is sent to the device and the operation is completed, it will always return a response. For a command that has no specific response the device will send back a single acknowledge byte called the **ACK (06hex)**, in the case of success, or **NAK (15hex)**, in the case of failure.

Commands having specific responses may send back varying numbers of bytes, depending upon the command and response. It will take the device a certain amount of time to respond, depending on the command type and the operation that has to be performed. If the MOTG device receives a command that it does not understand it will reply back with a negative acknowledge called the NAK (15hex). Since a command is only identified by its position in the sequence of data bytes sending incorrect data can result in wildly incorrect operation.

4. Command Set

The command interface between the MOTG device and the host is via the SPI interface. A handful of easy to learn commands provide complete access to all the available functions. The simplified command set also means that very low overheads are imposed on the host controller. Commands and responses can be either single bytes or many bytes. All commands return a response, either an acknowledge or data.

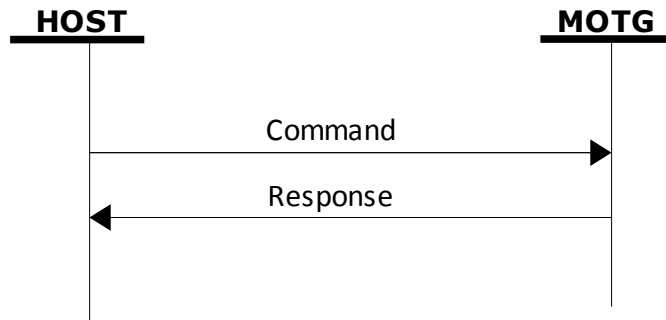

Each Command set is described in detail in the following sections.

MOTG-GPS Command Summary Table				
Cmd	Description	Sentence	Field Name	Returned Values
1	Returns Latest \$GPGGA sentence	\$GPGGA		Sentence as per section 5.1
2	Returns Latest \$GPGSA sentence	\$GPGSA		Sentence as per section 5.2
3	Returns Latest \$GPGSV sentence	\$GPGSV		Sentence as per section 5.3
4	Returns Latest \$GPRMC sentence	\$GPRMC		Sentence as per section 5.4
5	Returns Latest \$GPVTG sentence	\$GPVTG		Sentence as per section 5.5
A	Altitude above MSL (in tenths of meters, 65535 maximum)	\$GPGGA	MSL Altitude	nnn.n
L	Longitude	\$GPGGA	Longitude, E/W	dddmm.mmmm,EW
P	Latitude and Longitude	\$GPGGA	Latitude,N/S,Longitude,E/W	ddmm.mmmm,NS,dddmm.mmmm,EW
T	Latitude	\$GPGGA	Latitude, N/S	ddmm.mmmm,NS
C	Satellites used	\$GPGGA	Satellites Used	nn
F	Fix type	\$GPGSA	Mode 2	n
I	Satellites in View	\$GPGSV	Satellites in View	nn
M	Mode	\$GPVTG	Mode	c
D	Date (UTC/Greenwich Mean Time)	\$GPRMC	UTC Time	ddmmyy
E	Time (UTC/Greenwich Mean Time)	\$GPRMC	UTC Date	hhmmss.sss
N	Date and Time	\$GPRMC	UTC Date, UTC Time	ddmmyy, hhmmss.sss
H	Heading/Direction of travel (in tenths of degrees)	\$GPVTG	Course (True)	nnn.nn
K	Speed (in tenths of knots)	\$GPVTG	Speed (Knots)	n.nn
S	Speed (in tenths of km/hr)	\$GPVTG	Speed (km/hr)	n.nn
V	MOTG Module version	N/A		Device, Hardware, Firmware
d	Disables MOTG and places in low power mode	N/A		ACK (06hex)
e	Enables MOTG	N/A		ACK (06hex)
Note1: All commands are in ASCII.				
Note2: All returned values are ASCII and NULL terminated (unless otherwise indicated).				

4.1.1 Return Latest \$GPGGA Sentence – 1 (ascii)

Command	cmd	
	cmd	1(ascii) : Command byte
Response	Returns the latest \$GPGGA sentence as per section 5.1	
Description	This command requests the latest \$GPGGA NMEA sentence which includes GPS time, position and fix related data.	
Example	Command Data: 1 MOTG Response: \$GPGGA,064951.000,2307.1256,N,12016.4438,E,1,8,0.95,39.9,M,17.8,M,,*65	

4.1.2 Return Latest \$GPGSA Sentence – 2 (ascii)

Command	cmd	
	cmd	2(ascii) : Command byte
Response	Returns the latest \$GPGSA sentence as per section 5.2	
Description	This command requests the latest \$GPGSA NMEA sentence which includes GPS receiver operating mode, active satellites used in the position solution, and DOP values.	
Example	Command Data: 2 MOTG Response: \$GPGSA,A,3,29,21,26,15,18,09,06,10,,,,,2.32,0.95,2.11*00	

4.1.3 Return Latest \$GPGSV Sentence – 3 (ascii)

Command	cmd	
	cmd	3 (ascii) : Command byte
Response	Returns the latest \$GPGSV sentence as per section 5.3	
Description	<p>This command requests the latest \$GPGSV NMEA sentence which includes the number of GPS satellites in view, satellite ID numbers, elevation, azimuth, and SNR values.</p> <p>Note: The returned message may vary between 1 to 3 (depending on the number of satellites tracked, multiple messages of GSV data may be required.)</p>	
Example	<p>Command Data: 3</p> <p>MOTG Response: \$GPGSV,3,1,09,29,36,029,42,21,46,314,43,26,44,020,43,15,21,321,39*7D \$GPGSV,3,2,09,18,26,314,40,09,57,170,44,06,20,229,37,10,26,084,37*77 \$GPGSV,3,3,09,07,,,26*73</p>	

4.1.4 Return Latest \$GPRMC Sentence – 4 (ascii)

Command	cmd	
	cmd	4(ascii) : Command byte
Response	Returns the latest \$GPRMC sentence as per section 5.4	
Description	This command requests the latest \$GPRMC NMEA sentence which is the recommended minimum navigation information and includes : time, date, position, course and speed data.	
Example	Command Data: 4 MOTG Response: \$GPRMC,064951.000,A,2307.1256,N,12016.4438,E,0.03,165.48,260406,,,A*55	

4.1.5 Return Latest \$GPVTG Sentence – 5 (ascii)

Command	cmd	
	cmd	5(ascii) : Command byte
Response	Returns the latest \$GPVTG sentence as per section 5.5	
Description	This command requests the latest \$GPVTG NMEA sentence which includes course and speed information relative to ground.	
Example	Command Data: 5 MOTG Response: \$GPVTG,165.48,T,,M,0.03,N,0.06,K,A*37	

4.1.6 MSL Altitude – A (ascii)

Command	cmd	
	cmd	A(ascii) : Command header byte
Response	nnn.n <00hex>	
	nnn	Altitude in meters
	.	Decimal point indicator
	n	Altitude in 1/10 th meters
	<00hex>	1 byte NULL terminator
Description	This command returns the altitude above Mean Sea Level (in tenths of meters, 65535 maximum).	
Example	Command Data: A MOTG Response: 315.9<00hex>	

4.1.7 Longitude – L (ascii)

Command	cmd	
	cmd	L(ascii) : Command header byte
Response	dddmm.mmmm,EW <00hex>	
	dddmm	Longitude in degrees and minutes
	.	Decimal point indicator
	mmm	Longitude decimal fraction of minutes
	,	Comma separator
	EW	East or West Indicator (1 character)
	<00hex>	1 byte NULL terminator
Description	This command returns the Longitude in degrees and minutes as well as the East or West indicator.	
Example	Command Data: L MOTG Response: 12016.4438,E<00hex>	

4.1.8 Latitude and Longitude – P (ascii)

Command	cmd	
	cmd	P(ascii) : Command header byte
Response	ddmm.mmmm,NS,dddmm.mmmm,EW <00hex>	
	ddmm	Latitude in degrees and minutes
	.	Decimal point indicator
	mmmm	Latitude decimal fraction of minutes
	,	Comma separator
	NS	North or South Indicator (1 character)
	,	Comma separator
	dddmm	Longitude in degrees and minutes
	.	Decimal point indicator
	mmmm	Longitude decimal fraction of minutes
	,	Comma separator
	EW	East or West Indicator (1 character)
	<00hex>	1 byte NULL terminator
Description	This command returns the Latitude, the North/South indicator, the Longitude and the East/West indicator.	
Example	Command Data: P MOTG Response: 2307.1256,N,12016.4438,E<00hex>	

4.1.9 Latitude – T (ascii)

Command	cmd	
	cmd	T(ascii) : Command header byte
Response	ddmm.mmmm,NS <00hex>	
	ddmm	Latitude in degrees and minutes
	.	Decimal point indicator
	mmmm	Latitude decimal fraction of minutes
	,	Comma separator
	NS	North or South Indicator (1 character)
	<00hex>	1 byte NULL terminator
Description	This command returns the Latitude in degrees and minutes as well as the North or South indicator.	
Example	Command Data: T MOTG Response: 2307.1256,N<00hex>	

4.1.10 Satellites Used – C (ascii)

Command	cmd	
	cmd	C (ascii) : Command header byte
Response	nn <00hex>	
	nn	Number of Satellites used (range is 0 to 14). Note: This field will vary between 1 and 2 characters.
	<00hex>	1 byte NULL terminator
Description	This command returns the number of satellites used.	
Example	Command Data: C MOTG Response: 8<00hex>	

4.1.11 Fix Type - F (ascii)

Command	cmd	
	cmd	F(ascii) : Command header byte
Response	n <00hex>	
	n	Mode 2 Fix Type. n = 1: Fix not available n = 2: 2D (< 4 SVs used) n = 3: 3D (≥ 4 SVs used)
	<00hex>	1 byte NULL terminator
Description	This command returns the Fix type.	
Example	Command Data: F MOTG Response: 3<00hex>	

4.1.12 Satellites In View – I (ascii)

Command	cmd	
	cmd	I(ascii) : Command header byte
Response	nn <00hex>	
	nn	Number of Satellites that are in view.
	<00hex>	1 byte NULL terminator
Description	This command returns the number of satellites that are in view to the MOTG-GPS.	
Example	Command Data: I MOTG Response: 09<00hex>	

4.1.13 Mode - M (ascii)

Command	cmd	
	cmd	M (ascii) : Command header byte
Response	c <00hex>	
	c	Mode Type. c = A: Autonomous Mode c = D: Differential Mode c = E: Estimated Mode
	<00hex>	1 byte NULL terminator
Description	This command returns the Mode type used.	
Example	Command Data: M MOTG Response: A<00hex>	

4.1.14 Date (UTC/Greenwich Mean Time) – D (ascii)

Command	cmd	
	cmd	D (ascii) : Command header byte
Response	ddmmyy <00hex>	
	ddmmyy	days, months, years.
	<00hex>	1 byte NULL terminator
Description	This command returns the UTC date in days, months and years. 2 characters per each field.	
Example	Command Data: D MOTG Response: 220211<00hex>	

4.1.15 Time (UTC/Greenwich Mean Time) – E (ascii)

Command	cmd	
	cmd	E(ascii) : Command header byte
Response	hhmmss.sss <00hex>	
	hhmmss	hours, minutes, seconds.
	.	Decimal point indicator.
	sss	Decimal fraction of seconds.
	<00hex>	1 byte NULL terminator.
Description	This command returns the UTC time in hours, minutes, seconds and milliseconds.	
Example	Command Data: E MOTG Response: 064951.000<00hex>	

4.1.16 Date and Time (UTC/Greenwich Mean Time) – N (ascii)

Command	cmd	
	cmd	N(ascii) : Command header byte
Response	ddmmyy,hhmmss.sss <00hex>	
	ddmmyy	days, months, years.
	,	Comma separator
	hhmmss	hours, minutes, seconds.
	.	Decimal point indicator.
	sss	Decimal fraction of seconds.
	<00hex>	1 byte NULL terminator.
Description	This command returns the UTC date and time in days, months, years, hours, minutes, seconds and milliseconds.	
Example	Command Data: N MOTG Response: 220211,064951.000<00hex>	

4.1.17 Heading/Direction – H (ascii)

Command	cmd	
	cmd	H (ascii) : Command header byte
Response	nnn.nn <00hex>	
	nnn	Course in degrees
	.	Decimal point indicator
	nn	Fractions of degrees
	<00hex>	1 byte NULL terminator.
Description	This command returns the True Course of travel in degrees.	
Example	Command Data: H MOTG Response: 165.48<00hex>	

4.1.18 Speed in Knots – K (ascii)

Command	cmd	
	cmd	K(ascii) : Command header byte
Response	n.nn <00hex>	
	n	Speed in knots
	.	Decimal point indicator
	nn	Fractions of speed
	<00hex>	1 byte NULL terminator
Description	This command returns the measured horizontal speed in knots.	
Example	Command Data: K MOTG Response: 0.03<00hex>	

4.1.19 Speed in km/hr – S (ascii)

Command	cmd	
	cmd	S(ascii) : Command header byte
Response	n.nn <00hex>	
	n	Speed in km/hr
	.	Decimal point indicator
	nn	Fractions of speed
	<00hex>	1 byte NULL terminator
Description	This command returns the measured horizontal speed in km/hr.	
Example	Command Data: S MOTG Response: 0.06<00hex>	

4.1.20 Version-Device Info Request - V (ascii)

Command	Cmd	
	cmd	V(ascii) : Command header byte
Response	device_type, hardware_rev, firmware_rev <00hex>	
	device_type	This response indicates the device type. G = MOTG-GPS.
	,	Comma separator
	hardware_rev	This response indicates the device hardware version, current version = 0
	,	Comma separator
	firmware_rev	This response indicates the device firmware version, current version = 0
	<00hex>	1 byte NULL terminator
Description	This command requests all the necessary information from the device about its characteristics and capability.	

4.1.21 Disable MOTG – d (ascii)

Command	cmd	
	cmd	d (ascii) : Command header byte
Response	acknowledge	
	acknowledge	06 (hex) : ACK byte if successful 15 (hex) : NAK byte if unsuccessful
Description	This command disables the MOTG and puts it in low power mode.	

4.1.22 Enable MOTG – e (ascii)

Command	cmd	
	cmd	e (ascii) : Command header byte
Response	acknowledge	
	acknowledge	06 (hex) : ACK byte if successful 15 (hex) : NAK byte if unsuccessful
Description	This command enables the MOTG and takes it out of low power mode.	

5. NMEA Messages

The following table lists each of the NMEA output sentences and the following sections provide their relevant details. The individual command responses, in the previous section, are derived from these sentences.

NMEA OUTPUT SENTENCES	
Sentence	Description
GPGGA	Time, position and fix type data.
GPGSA	GPS receiver operating mode, active satellites used in the position solution, and DOP values.
GPGSV	The number of GPS satellites in view, satellite ID numbers, elevation, azimuth, and SNR values.
GPRMC	Time, date, position, course and speed data. Recommended Minimum Navigation Information.
GPVTG	Course and speed information relative to ground.

5.1 GPGGA – GPS Fixed Data. Time, Position and Fix Related Data.

This table contains the values for the following example :

\$GPGGA,064951.000,2307.1256,N,12016.4438,E,1,8,0.95,39.9,M,17.8,M,,*65

GPGGA Data Format			
Name	Example	Units	Description
Message ID	\$GPGGA		GGA protocol header
UTC Time	064951.000		hhmmss.sss
Latitude	2307.1256		ddmm.mmmm
N/S Indicator	N		N = North or S = South
Longitude	12016.4438		dddmm.mmmm
E/W Indicator	E		E = East or W = West
Position Fix Indicator	1		0: Fix not available 1: GPS Fix 2: Differential GPS Fix
Satellites Used	8		Range 0 to 14
HDOP	0.95		Horizontal Dilution of Precision
MSL Altitude	39.9	meters	MOTG-GPS Altitude above/below mean-sea-level
Units	M	meters	Units of antenna altitude
Geoidal Separation	17.8	meters	
Units	M	meters	Units of geoidal separation
Age of Diff. Corr.		second	Null fields when DGPS is not used
Checksum	*65		
<CR> <LF>			End of message termination

5.2 GPGSA – GNSS DOP and Active Satellites.

This table contains the values for the following example :

\$GPGSA,A,3,29,21,26,15,18,09,06,10,,,,,2.32,0.95,2.11*00

GPGSA Data Format			
Name	Example	Units	Description
Message ID	\$GPGSA		GSA protocol header
Mode 1	A		M: Manual—forced to operate in 2D or 3D mode A: 2D Automatic—allowed to automatically switch 2D/3D.
Mode 2	3		1: Fix not available 2: 2D (< 4 SVs used) 3: 3D (≥ 4 SVs used)
Satellite Used	29		SV on Channel 1
Satellite Used	21		SV on Channel 2
....
Satellite Used			SV on Channel 12
PDOP	2.32		Position Dilution of Precision
HDOP	0.95		Horizontal Dilution of Precision
VDOP	2.11		Vertical Dilution of Precision
Checksum	*00		
<CR> <LF>			End of message termination

5.3 GPGSV – GNSS Satellites in View.

This table contains the values for the following example :

\$GPGSV,3,1,09,29,36,029,42,21,46,314,43,26,44,020,43,15,21,321,39*7D

\$GPGSV,3,2,09,18,26,314,40,09,57,170,44,06,20,229,37,10,26,084,37*77

\$GPGSV,3,3,09,07,,,26*73

GPGSV Data Format			
Name	Example	Units	Description
Message ID	\$GPGSV		GSV protocol header
Number of Messages	3		Range 1 to 3 (Depending on the number of satellites tracked, multiple messages of GSV data may be required.)
Message Number1	1		Range 1 to 3
Satellites in View	09		
Satellite ID	29		Channel 1 (Range 1 to 32)
Elevation	36	degrees	Channel 1 (Maximum 90)
Azimuth	029	degrees	Channel 1 (True, Range 0 to 359)
SNR (C/No)	42	dBHz	Range 0 to 99, (null when not tracking)
....
Satellite ID	15		Channel 4 (Range 1 to 32)
Elevation	21	degrees	Channel 4 (Maximum 90)
Azimuth	321	degrees	Channel 1 (True, Range 0 to 359)
SNR (C/No)	39	dBHz	Range 0 to 99, (null when not tracking)
Checksum	*7D		
<CR> <LF>			End of message termination

5.4 GPRMC – Recommended Minimum Navigation Information.

This table contains the values for the following example :

\$GPRMC,064951.000,A,2307.1256,N,12016.4438,E,0.03,165.48,260406,,,A*55

GPRMC Data Format			
Name	Example	Units	Description
Message ID	\$GPRMC		RMC protocol header
UTC Time	064951.000		hhmmss.sss
Status	A		A = Data Valid or V = Data Not Valid
Latitude	2307.1256		ddmm.mmmm
N/S Indicator	N		N = North or S = South
Longitude	12016.4438		dddmm.mmmm
E/W Indicator	E		E = East or W = West
Speed Over Ground	0.03	knots	
Course Over Ground	165.48	degrees	True
Date	260406		ddmmyy
Magnetic Variation		degrees	E = East or W = West Note: MOTG-GPS does not support magnetic declination.
Mode	A		A: Autonomous Mode D: Differential Mode E: Estimated Mode
Checksum	*55		
<CR> <LF>			End of message termination

5.5 GPVTG – Course and Speed Information Relative to Ground.

This table contains the values for the following example :

\$GPVTG,165.48,T,,M,0.03,N,0.06,K,A*37

GPVTG Data Format			
Name	Example	Units	Description
Message ID	\$GPVTG		VTG protocol header
Course	165.48	degrees	Measured Heading
Reference	T		True
Course		degrees	Measured Heading
Reference	M		Magnetic Note: MOTG-GPS does not support magnetic declination.
Speed	0.03	knots	Measured Horizontal Speed
Units	N		Knots
Speed	0.06	km/hr	Measured Horizontal Speed
Units	K		Kilometers per hour
Mode	A		A: Autonomous Mode D: Differential Mode E: Estimated Mode
Checksum	*37		
<CR> <LF>			End of message termination

6.3 Programing the MOTG with a PmmC File

PmmC is an abbreviation of Personality-module-micro-Code. The GOLDLEOX chip used in the MOTG device is a custom controller and all functionality including the high level commands are built into the chip. This chip level configuration is available as a PmmC file and contains all of the low level micro-code information (analogy of that of a soft silicon) which define the characteristics and functionality of the MOTG device. The ability of programming the device with a PmmC file provides an extremely flexible method of customising as well as upgrading the MOTG with future enhancements.

As we make further improvements, we will release PmmC file updates and you should check regularly to benefit from these enhancements. You can download the latest version from here:

www.4dsystems.com.au/downloads/MOTG/MOTG-GPS/PmmC/Embedded/

To program the MOTG module with its PmmC file follow these steps:

- Download the [PmmC-Loader](#) Software tool.
- Run the PmmC Loader.
- Select the COM port your MOTG is attached to (using the Programming Cable & Adaptor).
- Select the MOTG PmmC file you've just downloaded. There's a small browser button on the right hand side to help you locate the file.
- Click the 'Load' button. The progress bar will inform you when the programming is done.

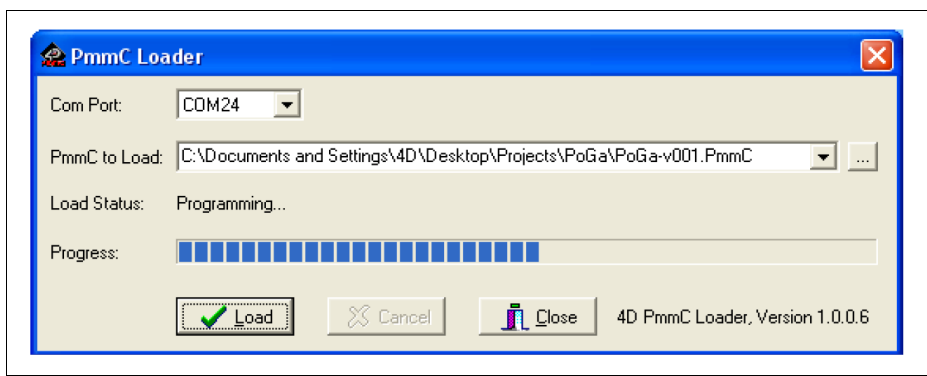

Note: The MOTG module is always shipped, factory programmed, with the latest PmmC file. It is advisable that you check regularly for the latest updates here:

www.4dsystems.com.au/downloads/MOTG/MOTG-GPS/PmmC/Embedded/

6.4 micro-SD to SD Adaptor

If your embedded hardware platform uses an SD connector, you'll need a micro-SD to SD adaptor. These should be readily available from most suppliers and are also available from 4D Systems online shopping cart.

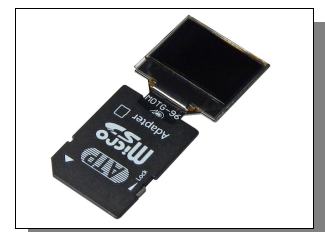

7. Specifications and Ratings

Absolute Maximum Ratings

Operating ambient temperature	-35°C to +75°C
Storage temperature	-40°C +80°C
Voltage on any digital input pin with respect to GND	-0.3V to 6.0V
Voltage on SWITCH pin with respect to GND	-0.3V to 6.0V
Voltage on VCC with respect to GND	-0.3V to 6.0V
Maximum current out of GND pin	300mA
Maximum current into VCC pin	250mA
Maximum output current sunk/sourced by any pin	4.0mA
Total power dissipation	1.0W

NOTE: Stresses above those listed here may cause permanent damage to the device. This is a stress rating only and functional operation of the device at those or any other conditions above those indicated in the recommended operation listings of this specification is not implied. Exposure to maximum rating conditions for extended periods may affect device reliability.

Recommended Operating Conditions

Parameter	Conditions	Min	Typ	Max	Units
Supply Voltage (VCC)		3.0	3.3	3.6	V
Operating Temperature		-30	--	+70	°C
Input Low Voltage	SDI, CS pins	GND	--	0.8	V
Input High Voltage	SDI, CS pins	2.0	3.3	5.0	V
Reset Pulse	External Open Collector	2.0	--	--	µs
Operational Delay	Power-Up or External Reset	1000	--	--	ms

Global Characteristics based on Operating Conditions

Parameter	Conditions	Min	Typ	Max	Units
Supply Current (ICC)	VCC = 3.3V	60	65	75	mA
Output Low Voltage (VOL)	SDO pin, IOL = 3.4mA	--	--	0.4	V
Output High Voltage (VOH)	SDO pin, IOL = -2.0mA	2.4	--	3.3	V
Capacitive Loading	All pins	--	--	50	pF
Flash Memory Endurance	MOTG PmmC Programming	--	1000	--	E/W

Ordering Information

Order Code: MOTG-GPS

Package: 150mm x 95mm (ZIF Bag dimensions).

Packaging: Module sealed in antistatic padded ZIF bag.

Proprietary Information

The information contained in this document is the property of 4D Systems Pty. Ltd. and may be the subject of patents pending or granted, and must not be copied or disclosed without prior written permission.

4D Systems endeavours to ensure that the information in this document is correct and fairly stated but does not accept liability for any error or omission. The development of 4D Systems products and services is continuous and published information may not be up to date. It is important to check the current position with 4D Systems.

All trademarks belong to their respective owners and are recognised and acknowledged.

Disclaimer of Warranties & Limitation of Liability

4D Systems makes no warranty, either express or implied with respect to any product, and specifically disclaims all other warranties, including, without limitation, warranties for merchantability, non-infringement and fitness for any particular purpose.

Information contained in this publication regarding device applications and the like is provided only for your convenience and may be superseded by updates. It is your responsibility to ensure that your application meets with your specifications.

In no event shall 4D Systems be liable to the buyer or to any third party for any indirect, incidental, special, consequential, punitive or exemplary damages (including without limitation lost profits, lost savings, or loss of business opportunity) arising out of or relating to any product or service provided or to be provided by 4D Systems, or the use or inability to use the same, even if 4D Systems has been advised of the possibility of such damages.

Use of 4D Systems' devices in life support and/or safety applications is entirely at the buyer's risk, and the buyer agrees to defend, indemnify and hold harmless 4D Systems from any and all damages, claims, suits, or expenses resulting from such use. No licenses are conveyed, implicitly or otherwise, under any 4D Systems intellectual property rights.

Contact Information

For Technical Support : support@4dsystems.com.au

For Sales Support : sales@4dsystems.com.au

Website : www.4dsystems.com.au

Copyright 4D Systems Pty. Ltd. 2000-2011.